

# *Recording acceleration in 3 directions*



*Ultra-compact data recorder that can record vibration, shock, temperature and humidity*



Shinyei Testing Machinery Co.,LTD

# *Challenges of logistics*

- Challenges at logistics site:
- Such as damage to the product due to a fall during the movement of cargo
- Load falling due to vibration during transportation,splitting off of load parts, etc..
- Condensation and other caused by sharp fluctuations in temperature and humidity



Firstly, in order to improve the quality of the logistics necessary to know the environment.



***Gravity Shock Recorder G-MEN***

***3-axis acceleration sensor, with temperature and humidity sensor built-in***

# Ultra-compact data recorder

## Writing the vibration and shock

### Characteristics of models

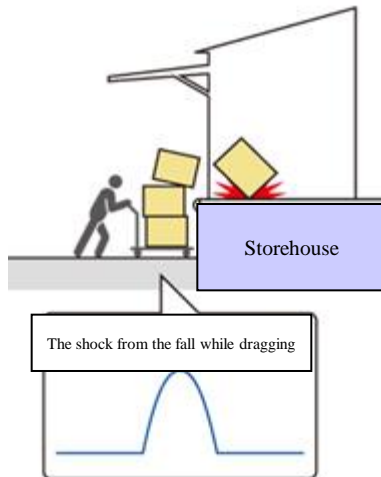

Measuring the shock during

the fall

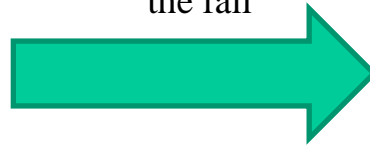

**Model: DR100**

- Maximum acceleration of 100G
- Temperature and humidity transmitter
- ※ Measurement up to 50 days
- ※ At the time of 10 ms sampling

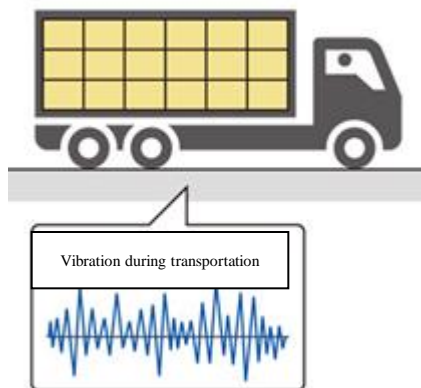

Measuring the vibration

during transportation

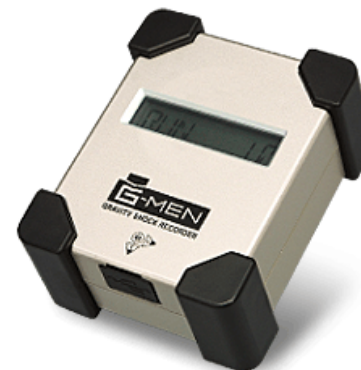

**Model : DR20**

- Maximum acceleration of 20G
- Temperature and humidity transmitter
- ※ Measurement up to 50 days
- ※ At the time of 10 ms sampling

# Ultra-compact data recorder

## Writing the vibration and shock



② Data recording in accordance with the measurement conditions

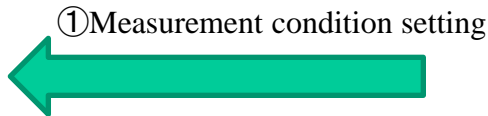

USB cable



③ Transmission of recorded data to PC



④ Displaying recorded data by special software

### Flow of data measurement

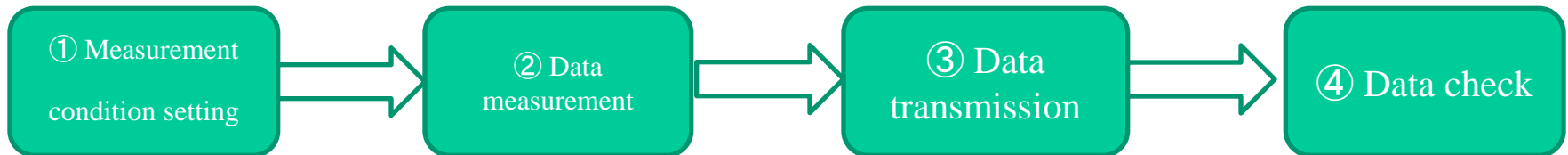

# Measurement Case-studies

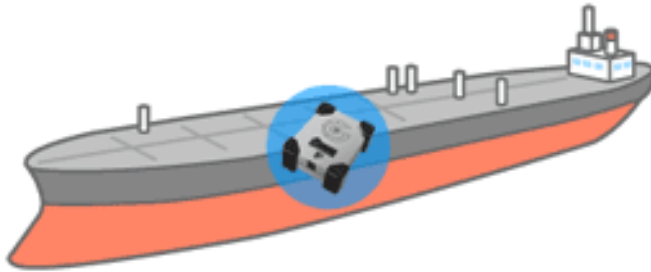

## Recording of ship vibrations

Measuring of ,depending on the wave ,back and forth, left and right, up and down motions of the ship traveling on the sea surface, by 3 directional acceleration data written by G-MEN

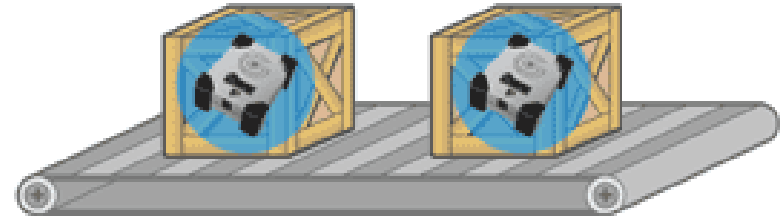

## Recording of conveyor line vibrations

The recorder being attached to such objects as straight parts, curve parts, joint and branching parts of the belt conveyor measures the vibration generated in those parts. Moreover, it also records the inclination angle of the inclined transporting unit.



## Quality guarantee check record of transported products

Monitoring the quality of transportation by recording the temperature changes, inclinations, shock and vibrations, by packing the recorder inside the transported product supplied with the special attention seal showing under what temperature it should be transported, and what vibration and shock can be applied.



## Transportation safety record of containers

We are analyzing the conditions of transportation routes by measuring over long periods of time the vibration and temperature of the interior of the container by mounting the body of recorder to a dedicated waterproof and dustproof case for measuring the condition of transportation of the containers.

## *Particular examples*

Example 1	Identifying problematic transportation routes with the help of G-MEN
Improvement	Modification of cushioning material on these routes and a reduction in the number of complaints
User	Communication equipment manufacturer
Example 2	Found that strong vibration that occurs during transport in trucks is the cause of parts splitting off.
Improvement	Solving problem by changing the route of transportation
User	Auto parts maker
Example 3	Using the G-MEN to ensure the safe transport of expensive equipment
Improvement	Provision of data to the client increases the client's confidence in the carriage
User	Auto parts maker

# Summary

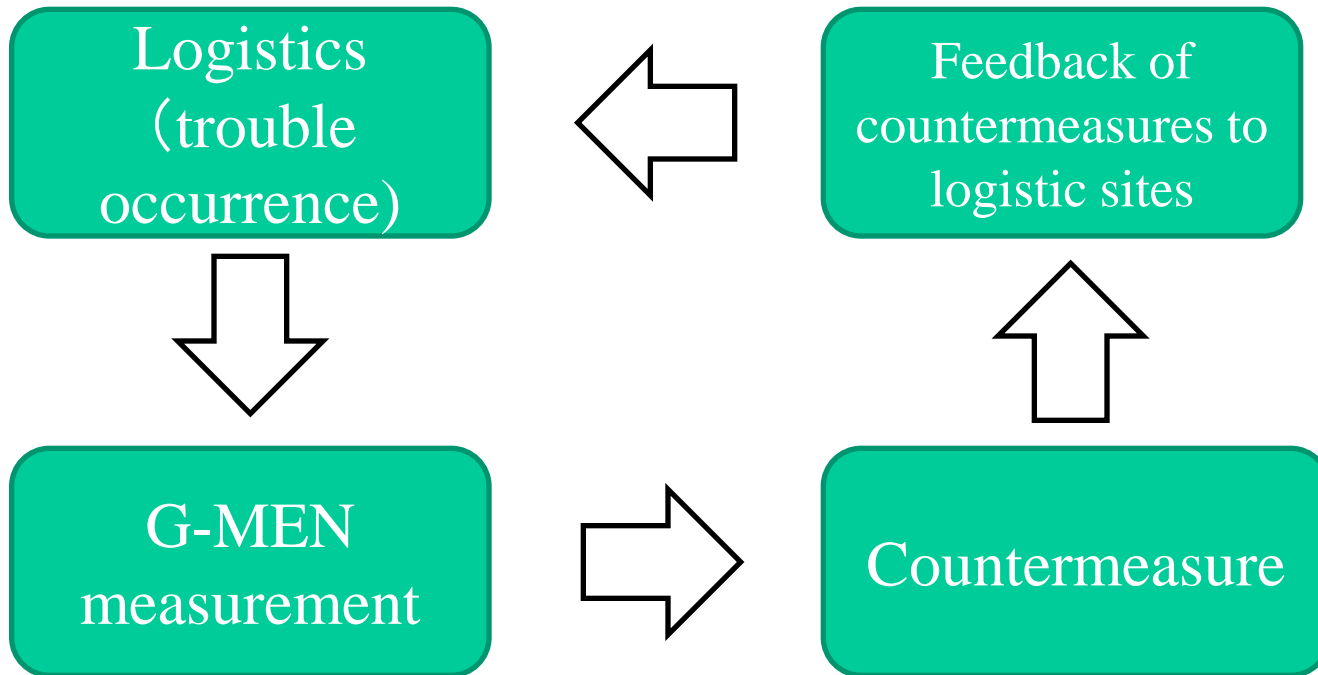

# *Supplemental material*



# *Ultra-compact data recorder*

## *Writing the vibration and shock*

### Spec of recorder body

Model	G-MEN DR01	G-MEN DR20	G-MEN DR100
Measurement item	Direct 3-axis acceleration peak value + temperature and humidity		
Acceleration sensor	Static acceleration 1G/2G	Static acceleration 10G/20G	Dynamic acceleration 100G
Sampling period	Selection from 1・2・5・10・20msec		
Measurement resolution	0.01G/0.02G	0.1G /0.2G	1G
Accuracy	±10%	±10%	±10%
Temperature range	0~50°C (±1.25°C)		
Humidity range	30~90% (±3%)		
Measurement interval	Selection from 1・5・10・15・20・30 sec・1・2・3・4・5・10・15・20・30 min		
Action display	Liquid crystal display		
Recording capacity	65,500 data		
Record keeping	EEPROM		
Communication format	USB (mini B)		
Continuous measurement time	Approx 50 days (in 10msec sampling period. Varies depending on setting conditions)		
Power supply	2 AA alkaline batteries		
External dimensions	75.5(H) × 60.5(W) × 33(D) mm		
Weight	135g (including batteries)		
Accessories	USB cable, 2 AA alkaline batteries, 1 attention seal, 1 complete of fixing metal fittings, special software (CD-ROM)		

Shinyei Testing Machinery Co., LTD

# Product outline *Description of parts*

Surface

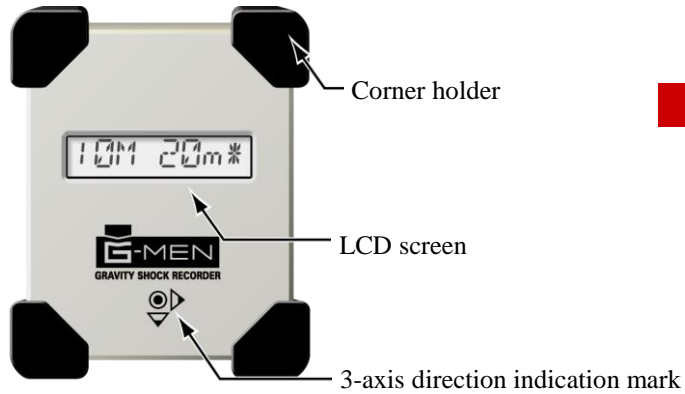

Back

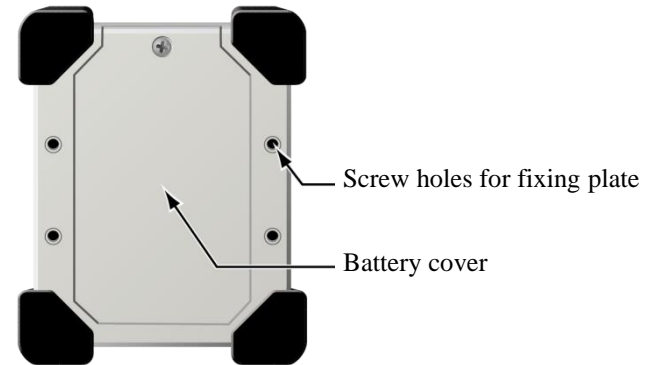

Bottom

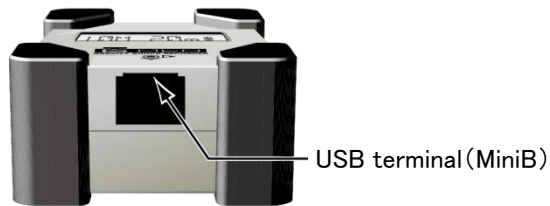

Battery case

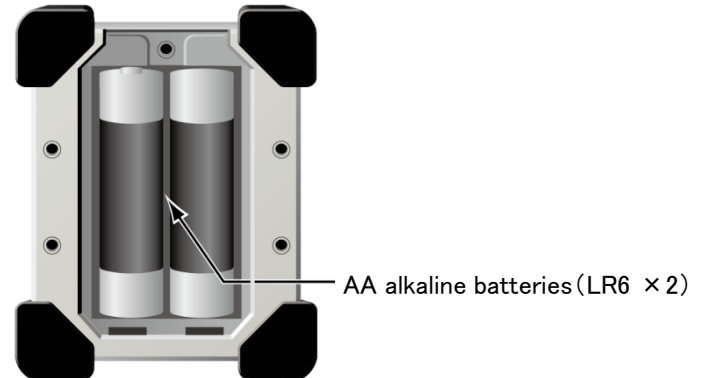

# Product outline *Connection to PC*

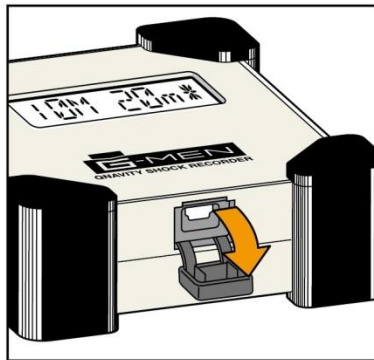

## **1** Open the connector cap

Open the connector cap of USB terminal (MiniB) body

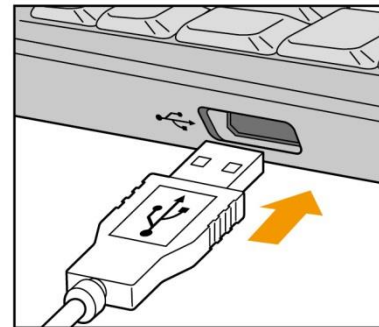

## **3** PC connection

Insert the USB TYPE- A side of the accessory USB cable into the USB connector on the PC

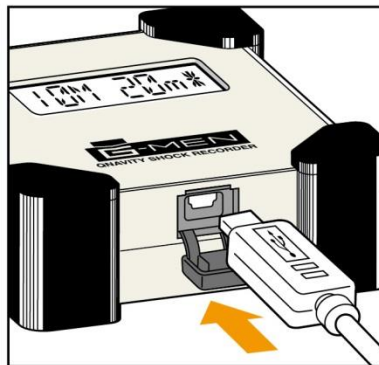

## **2** USB cable connection

Insert the USB terminal (MiniB) side of the accessory USB cable to the connector

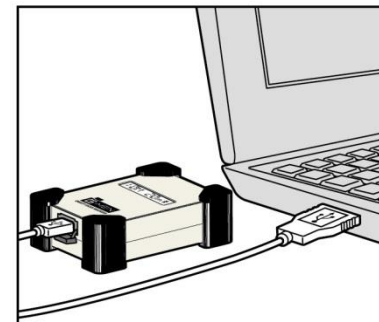

## **4** Communication with PC

Software of G- MEN will communicate with the installed PC.

# Product outline Body attachment method

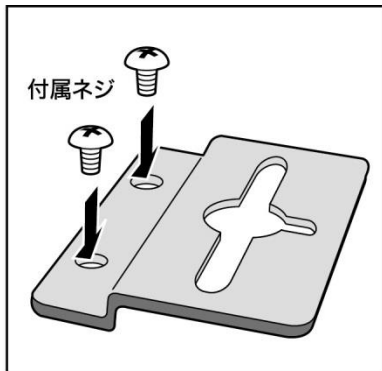

## 1 Mounting direction

Attach the body mounting fixed plate in this direction.

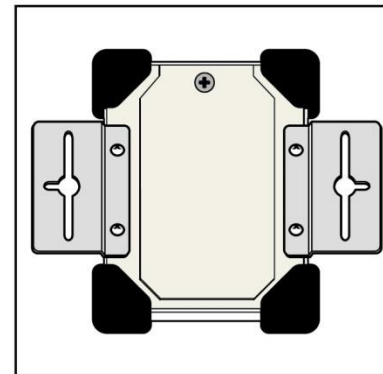

## 3 Mounting on both sides

Fasten attached body mounting fixed plate with screws on both sides.

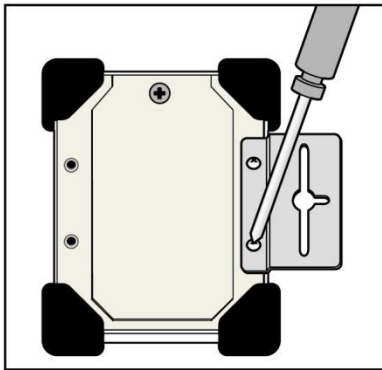

## 2 Mounting direction

Fasten the attached body mounting fixing plate with screws.

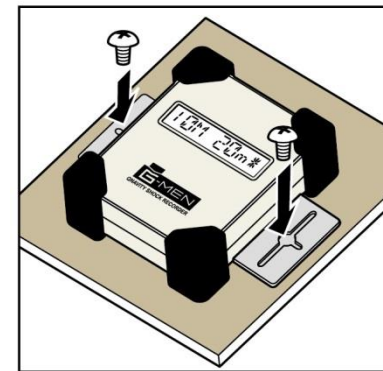

## 4 Fixed on object which is to be measured

Fix the fixing plate on both sides with screws to fit the object to be measured.

# Specific software Basic screen

## G-Trace.net

The screenshot shows the G-Trace.net software interface. At the top, there is a title bar and a menu bar with options like 'G-Tracenet スタートメニュー', '環境設定', 'ヘルプ', and '終了'. Below the menu bar is a tab bar with several tabs. A toolbar contains icons for '開く', '保存', '全て保存', 'CSV出力', '印刷', '再生', '抽出', and '表示設定'. Below the toolbar is a graph button area with options like 'グラフ縦軸', '100%', 'グラフ横軸', '加速度単位 G', '棒グラフ', '同時表示', and '独立表示'. The main area is a graph display screen showing a multi-axis time-series plot of acceleration data. The x-axis is labeled '時刻' and the y-axis is labeled 'XYZ軸(G)'. Below the graph is a list display screen with a table of data points.

No.	日付	時刻	X軸	Y軸	Z軸	合力	温度(C)	湿度(%)	備考
1	2011年7月30日	130200.000	0.000	0.000	-1.100	1.100	25.8	61.0	
2	2011年7月30日	130300.000	-1.400	-1.700	-3.300	3.367	26.0	73.0	
3	2011年7月30日	130400.000	0.000	0.000	-1.000	1.300	26.1	72.0	
4	2011年7月30日	130500.000	0.000	0.000	-1.000	1.300	26.1	72.0	
5	2011年7月30日	130600.000	1.700	1.500	-10.400	10.544	26.0	72.0	
6	2011年7月30日	130700.000	1.200	1.600	2.000	2.328	26.1	72.0	
7	2011年7月30日	130800.000	0.300	0.400	-0.900	1.300	26.1	72.0	
8	2011年7月30日	130900.000	0.500	-1.200	-0.100	1.304	26.1	71.0	
9	2011年7月30日	131000.000	0.700	-0.100	0.700	0.996	26.1	71.0	
10	2011年7月30日	131100.000	0.000	0.500	0.800	0.943	26.1	71.0	

ver 1.00.20604 | データ数: 16300 | サンプリング周期: 0.01秒 | 記録期間: 1分 | しゃい値: 0.0G | 本体番号: 1 | G-MEN 接続なし

# Special Software output

## G-Trace.net

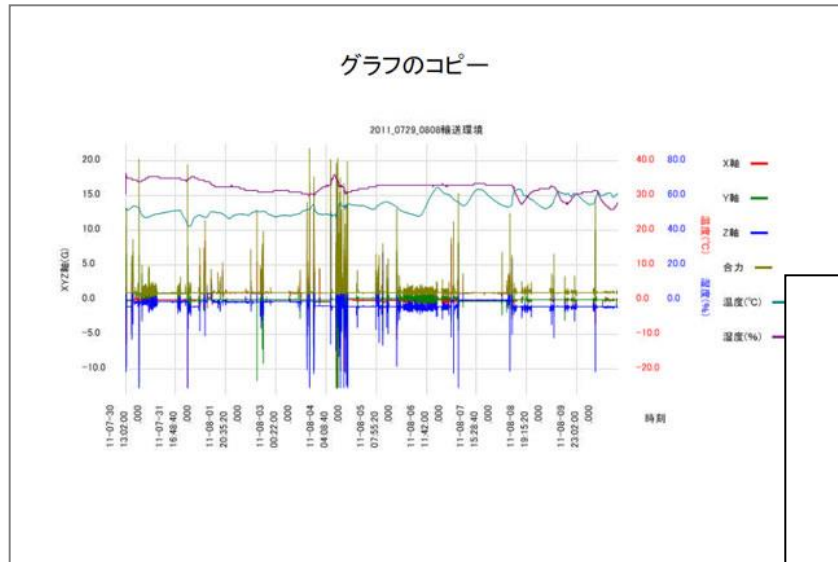

Graph display

Graph print out

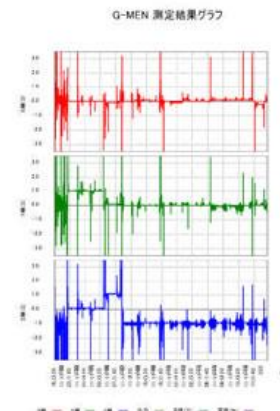

List print out

20111129番データ1 / 85

時刻	温度	湿度	X	Y	Z	合力
11-07-30 13:02:00	24.5	60.0	0.00	0.00	0.00	0.00
11-07-30 13:02:05	24.5	60.0	0.00	0.00	0.00	0.00
11-07-30 13:02:10	24.5	60.0	0.00	0.00	0.00	0.00
11-07-30 13:02:15	24.5	60.0	0.00	0.00	0.00	0.00
11-07-30 13:02:20	24.5	60.0	0.00	0.00	0.00	0.00
11-07-30 13:02:25	24.5	60.0	0.00	0.00	0.00	0.00
11-07-30 13:02:30	24.5	60.0	0.00	0.00	0.00	0.00
11-07-30 13:02:35	24.5	60.0	0.00	0.00	0.00	0.00
11-07-30 13:02:40	24.5	60.0	0.00	0.00	0.00	0.00
11-07-30 13:02:45	24.5	60.0	0.00	0.00	0.00	0.00
11-07-30 13:02:50	24.5	60.0	0.00	0.00	0.00	0.00
11-07-30 13:02:55	24.5	60.0	0.00	0.00	0.00	0.00
11-07-30 13:03:00	24.5	60.0	0.00	0.00	0.00	0.00
11-07-30 13:03:05	24.5	60.0	0.00	0.00	0.00	0.00
11-07-30 13:03:10	24.5	60.0	0.00	0.00	0.00	0.00
11-07-30 13:03:15	24.5	60.0	0.00	0.00	0.00	0.00
11-07-30 13:03:20	24.5	60.0	0.00	0.00	0.00	0.00
11-07-30 13:03:25	24.5	60.0	0.00	0.00	0.00	0.00
11-07-30 13:03:30	24.5	60.0	0.00	0.00	0.00	0.00
11-07-30 13:03:35	24.5	60.0	0.00	0.00	0.00	0.00
11-07-30 13:03:40	24.5	60.0	0.00	0.00	0.00	0.00
11-07-30 13:03:45	24.5	60.0	0.00	0.00	0.00	0.00
11-07-30 13:03:50	24.5	60.0	0.00	0.00	0.00	0.00
11-07-30 13:03:55	24.5	60.0	0.00	0.00	0.00	0.00
11-07-30 13:04:00	24.5	60.0	0.00	0.00	0.00	0.00
11-07-30 13:04:05	24.5	60.0	0.00	0.00	0.00	0.00
11-07-30 13:04:10	24.5	60.0	0.00	0.00	0.00	0.00
11-07-30 13:04:15	24.5	60.0	0.00	0.00	0.00	0.00
11-07-30 13:04:20	24.5	60.0	0.00	0.00	0.00	0.00
11-07-30 13:04:25	24.5	60.0	0.00	0.00	0.00	0.00
11-07-30 13:04:30	24.5	60.0	0.00	0.00	0.00	0.00
11-07-30 13:04:35	24.5	60.0	0.00	0.00	0.00	0.00
11-07-30 13:04:40	24.5	60.0	0.00	0.00	0.00	0.00
11-07-30 13:04:45	24.5	60.0	0.00	0.00	0.00	0.00
11-07-30 13:04:50	24.5	60.0	0.00	0.00	0.00	0.00
11-07-30 13:04:55	24.5	60.0	0.00	0.00	0.00	0.00
11-07-30 13:05:00	24.5	60.0	0.00	0.00	0.00	0.00
11-07-30 13:05:05	24.5	60.0	0.00	0.00	0.00	0.00
11-07-30 13:05:10	24.5	60.0	0.00	0.00	0.00	0.00
11-07-30 13:05:15	24.5	60.0	0.00	0.00	0.00	0.00
11-07-30 13:05:20	24.5	60.0	0.00	0.00	0.00	0.00
11-07-30 13:05:25	24.5	60.0	0.00	0.00	0.00	0.00
11-07-30 13:05:30	24.5	60.0	0.00	0.00	0.00	0.00
11-07-30 13:05:35	24.5	60.0	0.00	0.00	0.00	0.00
11-07-30 13:05:40	24.5	60.0	0.00	0.00	0.00	0.00
11-07-30 13:05:45	24.5	60.0	0.00	0.00	0.00	0.00
11-07-30 13:05:50	24.5	60.0	0.00	0.00	0.00	0.00
11-07-30 13:05:55	24.5	60.0	0.00	0.00	0.00	0.00
11-07-30 13:06:00	24.5	60.0	0.00	0.00	0.00	0.00
11-07-30 13:06:05	24.5	60.0	0.00	0.00	0.00	0.00
11-07-30 13:06:10	24.5	60.0	0.00	0.00	0.00	0.00
11-07-30 13:06:15	24.5	60.0	0.00	0.00	0.00	0.00
11-07-30 13:06:20	24.5	60.0	0.00	0.00	0.00	0.00
11-07-30 13:06:25	24.5	60.0	0.00	0.00	0.00	0.00
11-07-30 13:06:30	24.5	60.0	0.00	0.00	0.00	0.00
11-07-30 13:06:35	24.5	60.0	0.00	0.00	0.00	0.00
11-07-30 13:06:40	24.5	60.0	0.00	0.00	0.00	0.00
11-07-30 13:06:45	24.5	60.0	0.00	0.00	0.00	0.00
11-07-30 13:06:50	24.5	60.0	0.00	0.00	0.00	0.00
11-07-30 13:06:55	24.5	60.0	0.00	0.00	0.00	0.00
11-07-30 13:07:00	24.5	60.0	0.00	0.00	0.00	0.00
11-07-30 13:07:05	24.5	60.0	0.00	0.00	0.00	0.00
11-07-30 13:07:10	24.5	60.0	0.00	0.00	0.00	0.00
11-07-30 13:07:15	24.5	60.0	0.00	0.00	0.00	0.00
11-07-30 13:07:20	24.5	60.0	0.00	0.00	0.00	0.00
11-07-30 13:07:25	24.5	60.0	0.00	0.00	0.00	0.00
11-07-30 13:07:30	24.5	60.0	0.00	0.00	0.00	0.00
11-07-30 13:07:35	24.5	60.0	0.00	0.00	0.00	0.00
11-07-30 13:07:40	24.5	60.0	0.00	0.00	0.00	0.00
11-07-30 13:07:45	24.5	60.0	0.00	0.00	0.00	0.00
11-07-30 13:07:50	24.5	60.0	0.00	0.00	0.00	0.00
11-07-30 13:07:55	24.5	60.0	0.00	0.00	0.00	0.00
11-07-30 13:08:00	24.5	60.0	0.00	0.00	0.00	0.00
11-07-30 13:08:05	24.5	60.0	0.00	0.00	0.00	0.00
11-07-30 13:08:10	24.5	60.0	0.00	0.00	0.00	0.00
11-07-30 13:08:15	24.5	60.0	0.00	0.00	0.00	0.00
11-07-30 13:08:20	24.5	60.0	0.00	0.00	0.00	0.00
11-07-30 13:08:25	24.5	60.0	0.00	0.00	0.00	0.00
11-07-30 13:08:30	24.5	60.0	0.00	0.00	0.00	0.00
11-07-30 13:08:35	24.5	60.0	0.00	0.00	0.00	0.00
11-07-30 13:08:40	24.5	60.0	0.00	0.00	0.00	0.00
11-07-30 13:08:45	24.5	60.0	0.00	0.00	0.00	0.00
11-07-30 13:08:50	24.5	60.0	0.00	0.00	0.00	0.00
11-07-30 13:08:55	24.5	60.0	0.00	0.00	0.00	0.00
11-07-30 13:09:00	24.5	60.0	0.00	0.00	0.00	0.00