



Salt Spray Test Chamber Model SSE



Specification/Model	SS600e	SS1000e	SS1300e	SS3000e
Chamber Temperature Range	Ambient + 9°F (5°C) - +131°F (55°C)			
Bubble Tower Temperature	Ambient + 9°F (5°C) - +165°F (74°C)			
Bubble Tower with constant level, no auxiliary tank necessary for long duration test				
Centralized Atomization Nozzle with distribution tower and cone in accordance with: ASTM B117, pg. 4, Annex A ISO 9227, JIS Z 2371				
Approximated internal cabinet volum (liters)	600	1,000	1,300	3,000

- 1 – Indirect Heating through water jacket according to ASTM B-117 to ensure that no metallic heating will affect corrosivity of testing results.
- 2 - Lid engineered with smooth surface, without seams, per ASTM B-117, for prevention of contamination from solution drip.
- 3 - Unibody construction incorporating solution tank, bubble tower in one cabinet.
- 4- Central Atomization Tower engineered to ASTM B 117 standards ensuring fog uniformity and homogenous results.

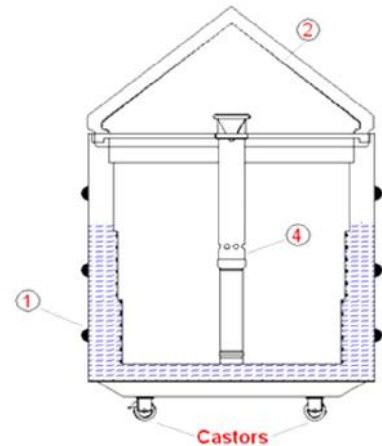

Data Acquisition Software - option:
 - By PC (RS 232, USB or RS 485)

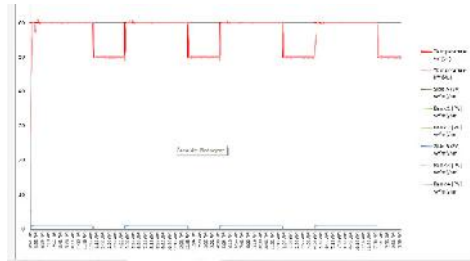









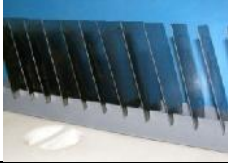





UL508A Compliance		Included		
Lid security system		Included		
Visual and audible security system		Included		
Internal Dimensions W x D x H (mm)	820 x 650 x 780	1,190 x 820 x 830	1,400 x 850 x 850	2,050 x 1,080 x 1,000
External Dimensions W x D x H (mm)	1,460 x 1,100 x 1,440	1,870 x 1,125 x 1,650	2,420 x 1,150 x 1,700	3,400 x 1,600 x 1,800
Approx. Crated Dimensions W x D x H (mm)	1,600 x 1,150 x 1,700	2,050 x 1,300 x 1,900	2,600 x 1,300 x 1,850	3,550 x 1,700 x 2,110
Approximate net weight	205 kg	210 kg	364 kg	550 kg
Approximate Shipping Weight - Crated	258 kg	280 kg	417 kg	850 kg
Approximate test volume in liters (L)	600	1,000	1,300	3,000
Recommended Lab conditions	Temperature: 63 °F (17°C) - 82°F (28°C), Relative humidity: Maximum 85% (without condensation)			
Electrical Supply	208 - 230 V Ø1 50/60Hz			
FLA (230V)	25A	35A		
Test water requirement	ASTM D 1193 Type IV			



DI water pressure	7 to 28 psi (0.5 to 2.0 kgf/cm ²)	
DI water input Ø	1/2"	
Constant Pressure	56 psi +/- 0.7 psi (4 kgf/cm ²)	
Water Supply	Chamber cleaning	
Corrosive Agent	Per Standard	
Lab exhaust	Fume Hood and motor – if necessary	
Drain	½" PVC tubing or PVC drain 4" at least	
Chamber exhaust	PVC 2" pipe without siphon	4"
Measurement items: pH, Conductivity NaCl concentration	In accordance with ASTM B 117, JIS Z 2374, ISO 9227	
Service Area	minimum of 19.6" (50 cm) for an easier cleaning, assembling and maintenance	
<p>1 (One) Year Parts Warranty against manufacturing defects from date of delivery at customer's site. This assumes equipment is used under normal operating conditions in accordance to the instruction manual. This warranty does not apply to glassware (lamps). In case of non-warranty issues during warranty period, actual expenses shall apply.</p>		
<p>Note 1: All our equipment is delivered with Installation, Maintenance and User Manual. We believe this material is enough for the correct use of the equipment. We are available for further questions and clarifications. Additionally, if desired, we can provide the technicians to assemble the equipment and conduct staff training at the client's site. (Cost available upon request).</p>		
<p>Note 2: Appearance and specifications of equipment are subject to change without prior notice.</p>		
<p>Note 3: We highly recommend that you don't use the same chamber for different solutions, e.g. don't use a Salt Spray chamber for CASS; Kesternich (SO₂) test or CASS chamber for humidity test due the chemical contamination that may distort the results. See item 4.6 of Standard ISO 9227.</p>		

Optional Accessories

<ul style="list-style-type: none"> • (1) rack - 15° or 20° inclination in accordance with ASTM B117 and ISO 9227. 	
<ul style="list-style-type: none"> • Special rack for customer supplied test sample. 	<p>Factory Consult</p>
<ul style="list-style-type: none"> • (2) Fog collectors. 	
<ul style="list-style-type: none"> • Pressure regulator with water, oil filter and pressure gauge. 	
<ul style="list-style-type: none"> • Fiberglass Fume Hood (hood only). 	
<ul style="list-style-type: none"> • Fiberglass axial fan assembly capacity: 1940 cfm. Net weight: 88 lbs.(40 kg). 	
<ul style="list-style-type: none"> • DI Water assembly includes: activated carbon water filter, DI column, LED water quality indicator. 	
<ul style="list-style-type: none"> • Spare DI water column. 	
<ul style="list-style-type: none"> • Spare activated carbon water filter. 	
<ul style="list-style-type: none"> • Density meter to measure concentration of saline solution in accordance to ASTM B 117. 	
<ul style="list-style-type: none"> • 6 x 2.20 = 13.2 lbs. (6 x 1 = 6Kg) of NaCl. 	

<ul style="list-style-type: none"> • Test Panels – 2.9" x 5" (76mm x 127mm). In accordance with ASTM B 117 (100 Pieces). 	
<ul style="list-style-type: none"> • Test Panels – 2.7" x 5.9" (70mm x 150mm). In accordance with ISO 9227 (100 pieces). 	
<ul style="list-style-type: none"> • Data Acquisition Software: - By PC (RS 232 or USB) 	
<ul style="list-style-type: none"> • Grid type test brackets supports 120 kg with distributed load. 	
<ul style="list-style-type: none"> • Cable port $\varnothing = 2''$– EQOP 0034 	

Further optional requests shall be considered upon request.

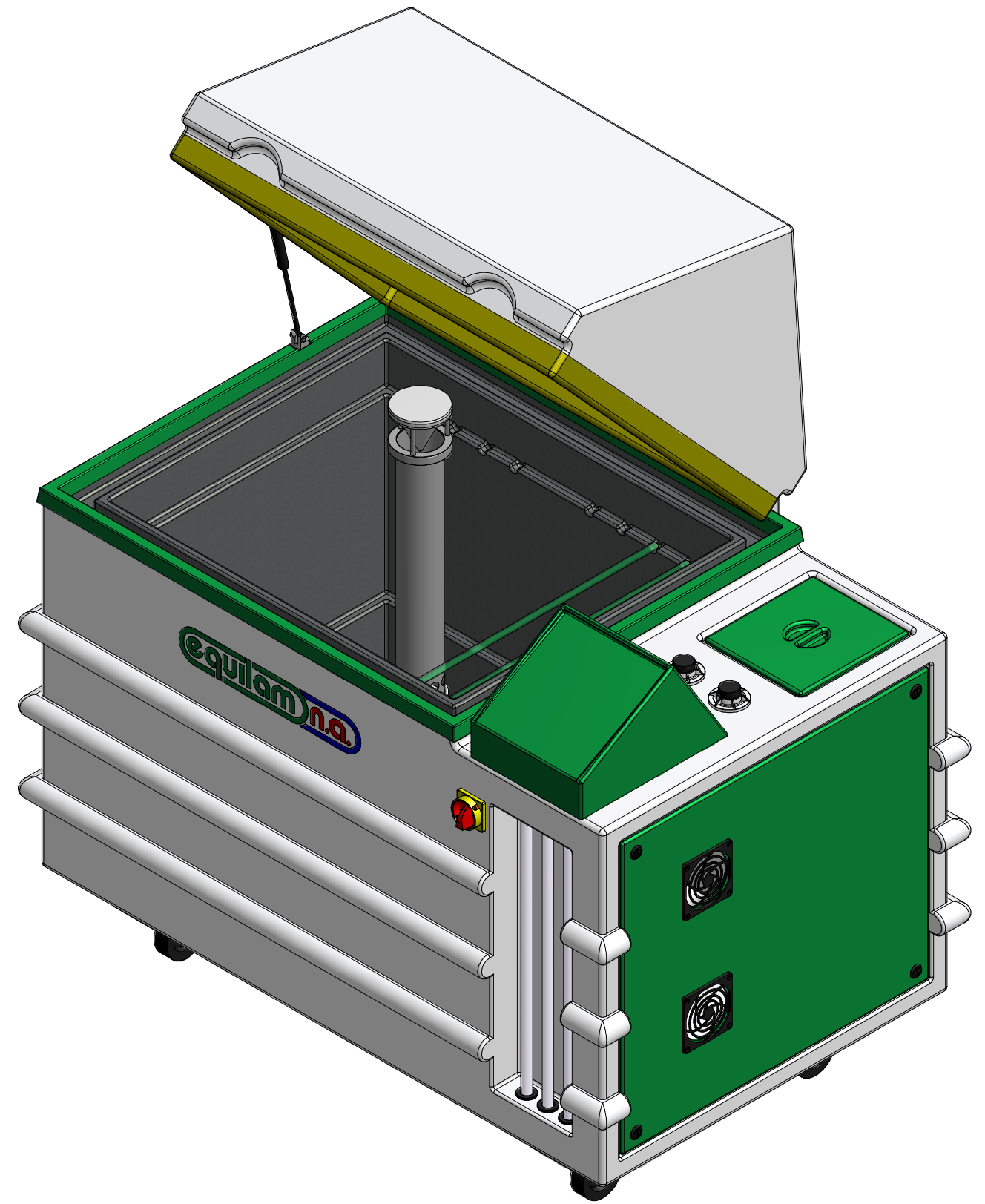
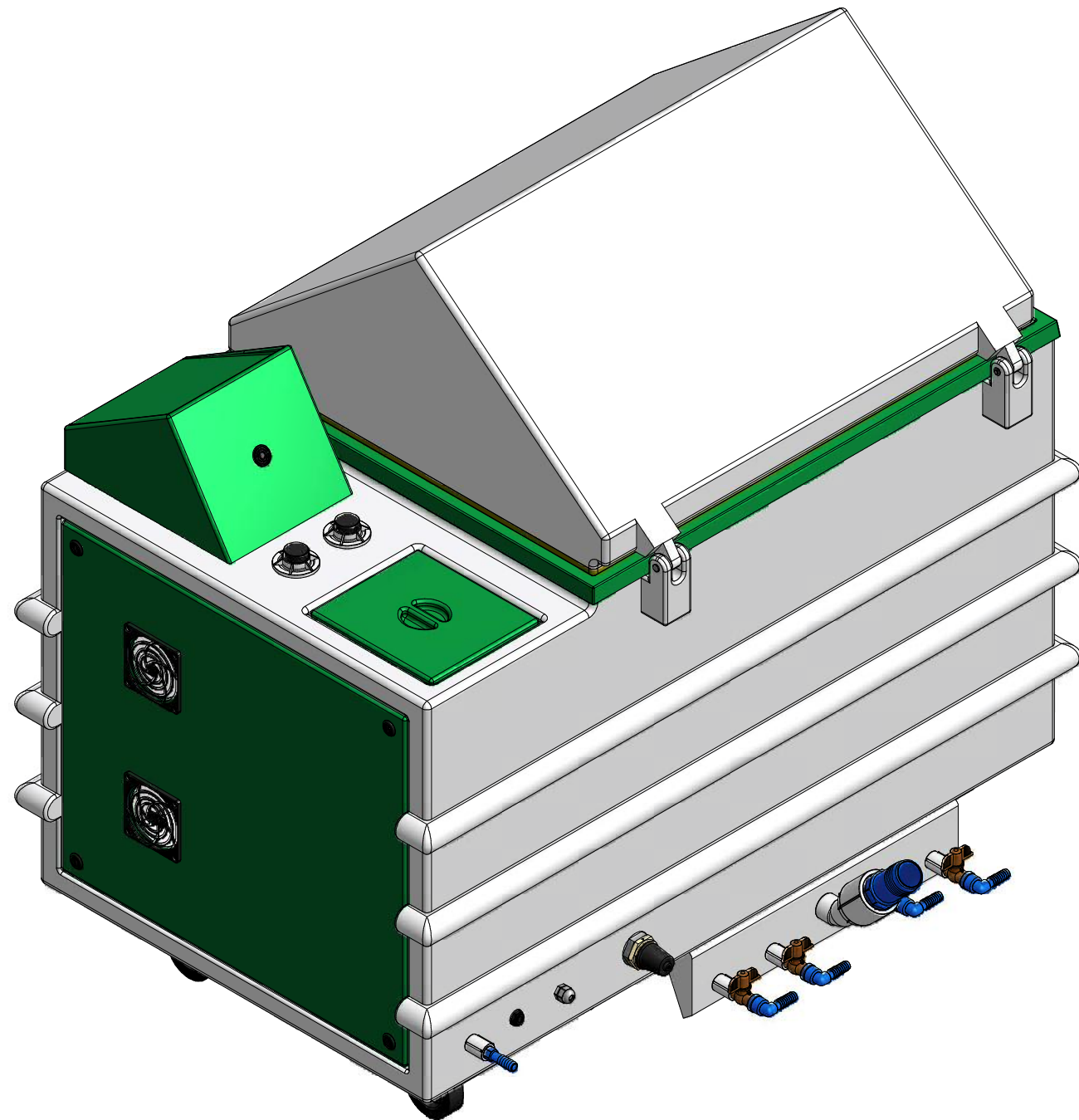

Date:
06/21/2016

Sheet:
A3

No.

www.equilamna.com

Description: Specification Sheet

Project: SSe

Rev.01

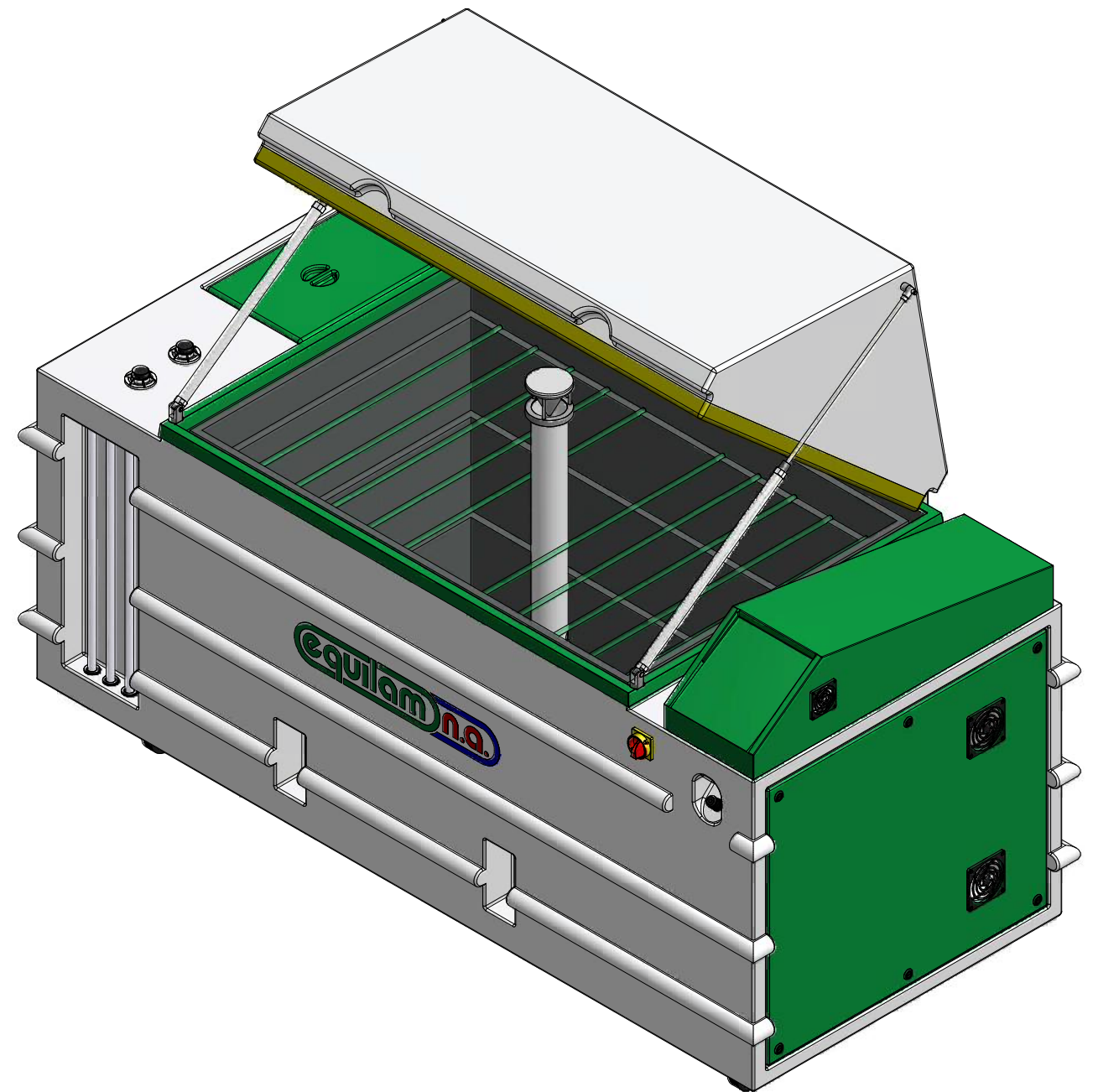
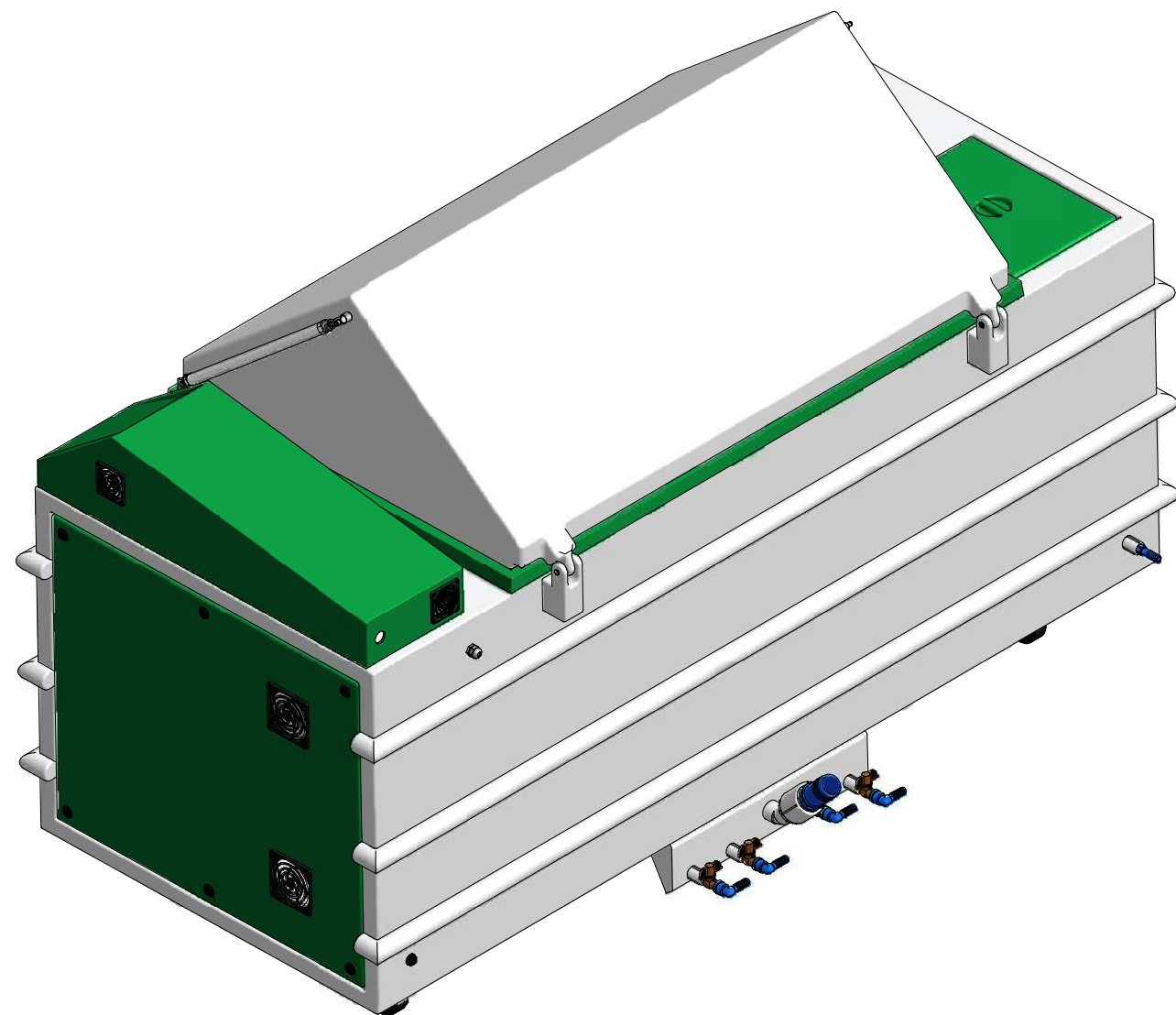

Date:
06/21/2016

Sheet:
A3

No.

www.equilamna.com

Description: Specification Sheet

Project: SS1300e

Rev.01

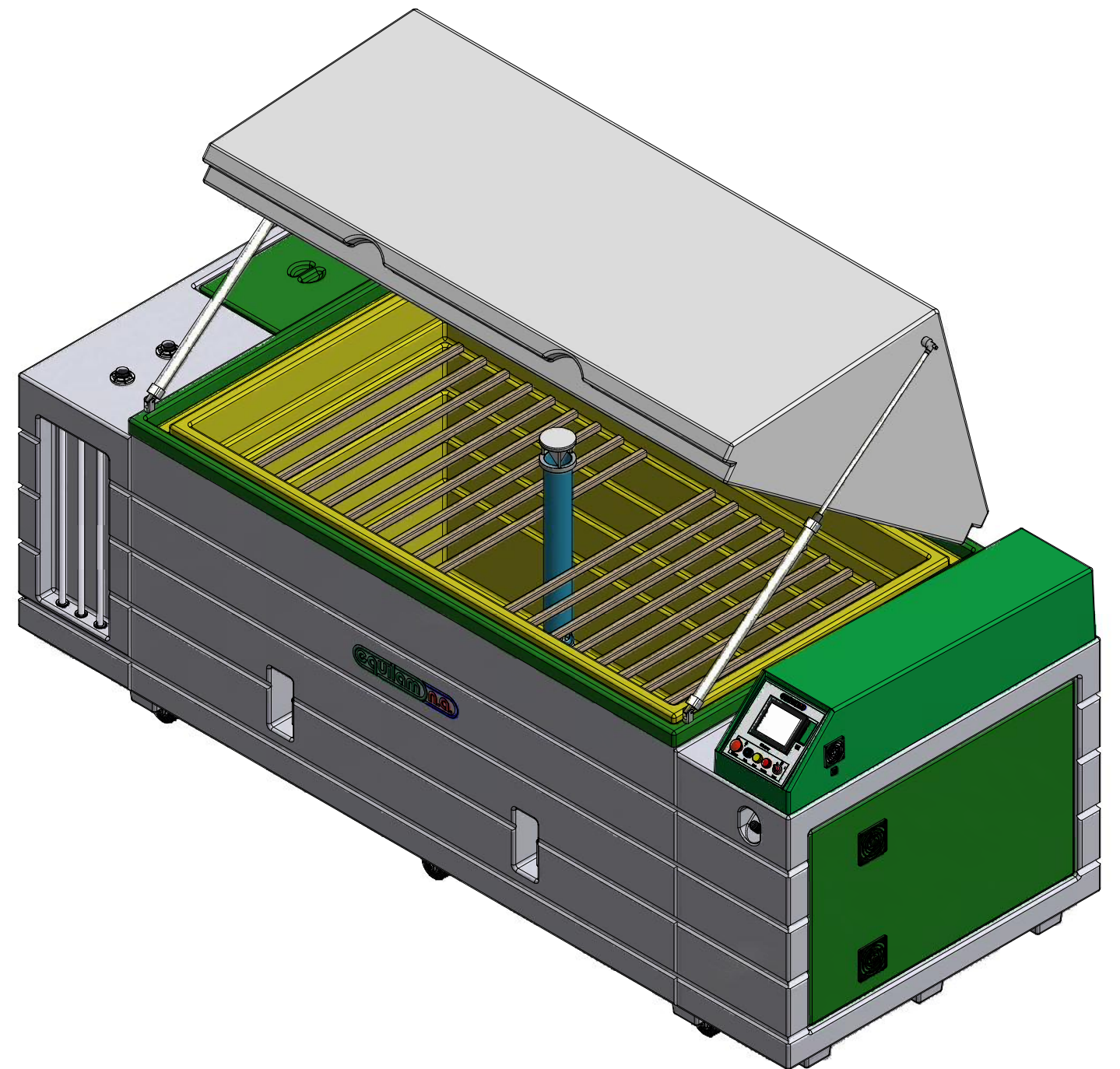
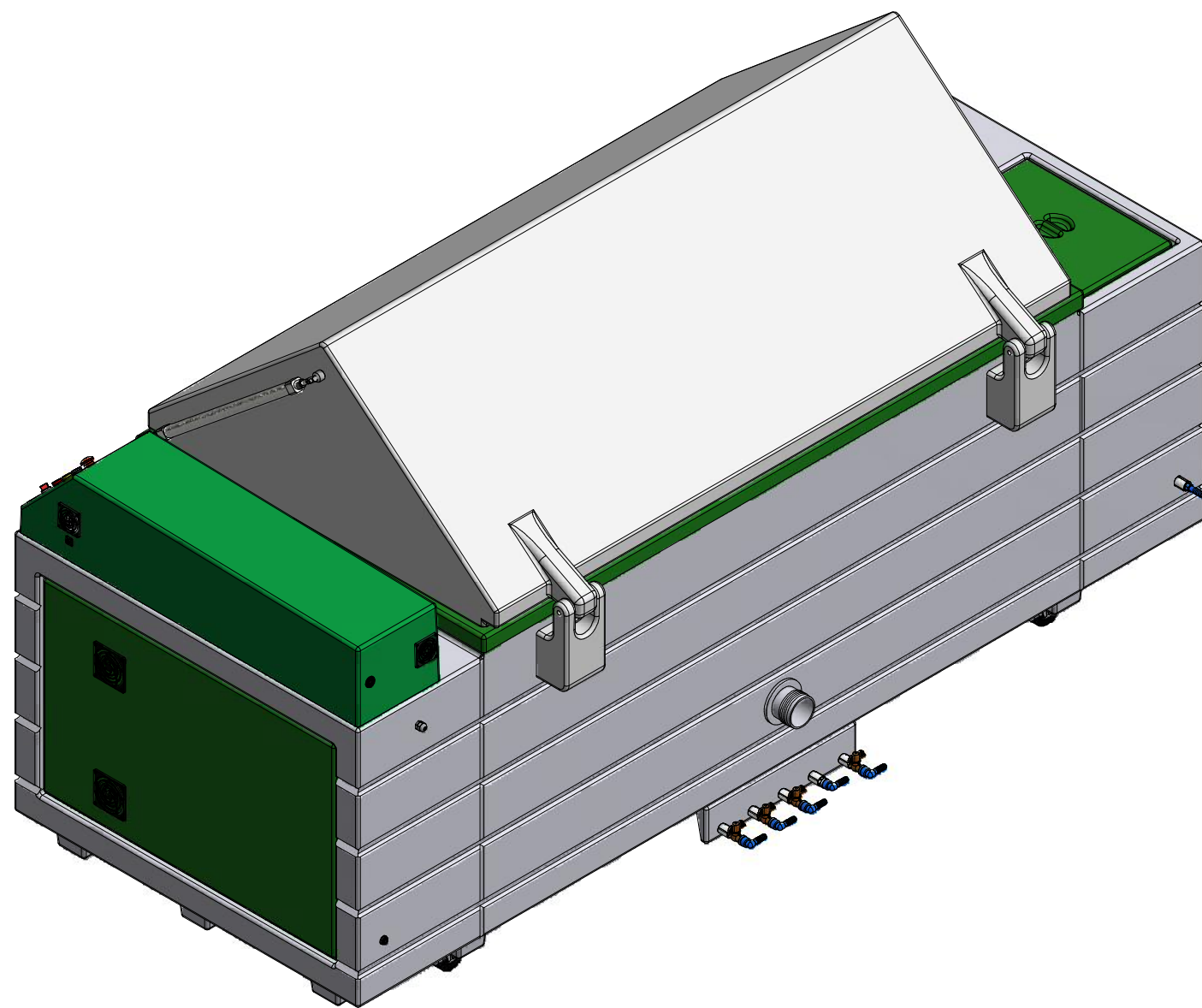

Date:
04/25/2017

Sheet:
A3

No.

www.equilamna.com

Description: Specification Sheet

Project: SSe-3000

Rev.01