

Drop Tester for Light Weight Products

DT-202

The DT-202 is a testing machine widely employed primarily in the drop testing of cellular phones. Its application, however, is not only limited to the testing of mobile phones, but also extends to shock resistance tests of a broad variety of devices, including HDDs, PDAs, digital audio players, etc., as well as their mechanism parts, circuit boards, and electronic components.

The machine can drop "lightweight" and "downsized" test samples stably maintained in any desired attitude. The main body of the tester in itself is compact and can be used in all industrial areas, including those of electronics, medicine, cosmetics, and others.

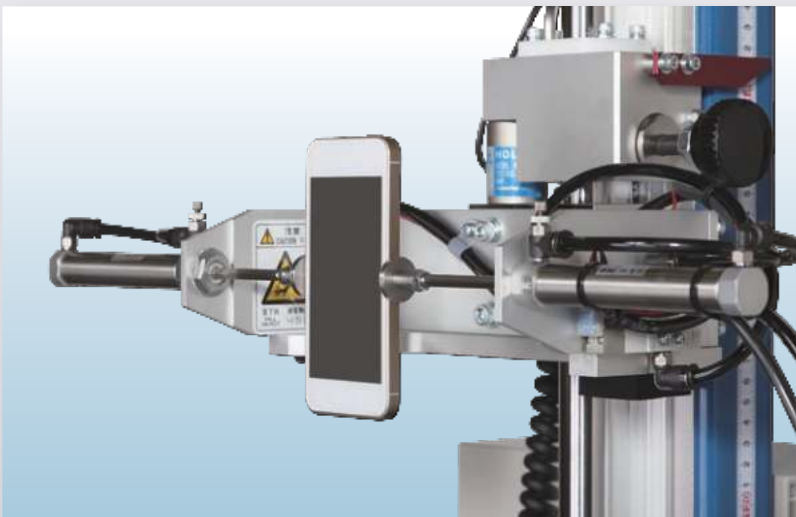

Specification

Max. mass of test sample: 2kg

Drop height range: 250mm - 2,000mm

Drop height setting method: By the scale and setting guideline.

Drop motion of test sample support table: By the permanent electromagnetic holder.

Fastening and dropping operation of test sample: By the pneumatic pen cylinder.

Installation size of tester: W:600mm x D:500mm

Dimensions of tester: W:600mm x D:500mm x H2,382mm

Mass of tester: Approx. 80kg

Power supply: 100V - 240V AC, single-phase, 5A

Feed air pressure: 0.49MPa or higher, 1.2dm³ (when operated 6 times/min.) or more

Operating environment temperature range: 5°C - 35°C



Max. mass of
test sample
2kg

Drop height range of test sample **250~2,000mm**

Installation size of tester
600x500mm

Drop Tester for Lightweight Products, designed compact and capable of meeting the needs of diverse sectors, including that of digital mobile products, etc.

Simple operation

- The test sample can be held in any attitude, dropped in a free fall, and the shock resistance, tested.
- The drop height can be set in a simple manner with the scale.
- The test sample is fastened by the pneumatic pen cylinder.

Sample applications:

- Can drop test a great variety of small-sized products, including mobile devices, such as cellular phones and PDAs, diverse electronic devices, PCBs, cosmetics, medical products, and others.
- When coupled with our analysis system (Shock Manager SM-500), the machine is able to measure various accelerations and analyze their data.

Sample configuration of analysis system with high-speed camera

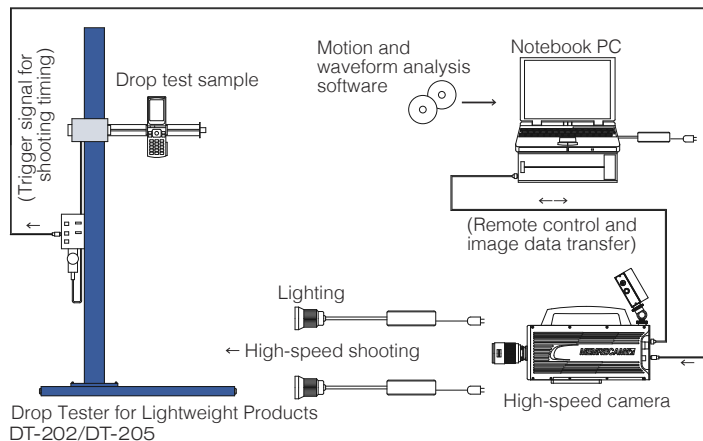

Dimension

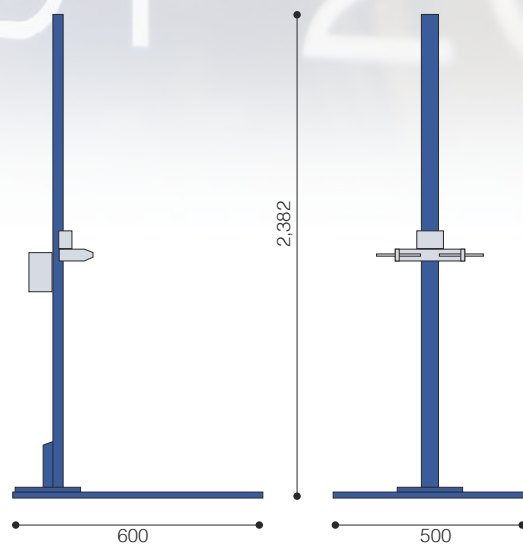

•Detailed view of support section

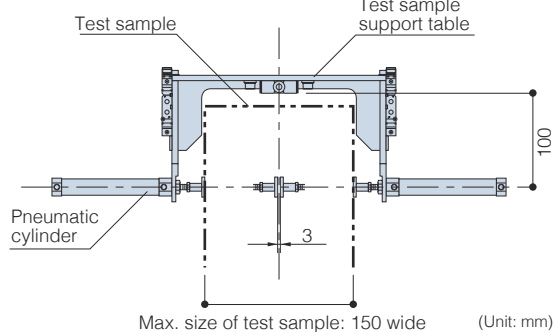

Consult us if your testing need exceeds the range specified above.

When an analysis system is built up using a high-speed camera, "shocks" can be observed visually. (High-speed shooting of a PCB under drop test)



Shinyei Group,
Your partner for prosperous society
SHINYEI SHINYEI TESTING MACHINERY CO., LTD.

<http://www.yoshida-seiki.com>

Head Office

Address: B47-11, Katoridai, Tsukuba, Ibaraki, 300-2657, JAPAN

Tel: +81-29-848-3571 FAX: +81-29-848-3572

Kobe Office

Address: Shinyei BLDG. 5F, 77-1, Kyomachi, Chuoku, Kobe, 650-0034, JAPAN

Tel: +81-78-392-6963 FAX: +81-78-332-1619

Specifications and information listed in this catalog are subject to change without notice. 201505